

# Specification

March 2023

---

Product: TFT LCD Display

APT Model: 750CM

Client Model:

---

Client:

Client Check :

---

Supplier : APT(Tianjin) Development Co., Ltd.  
1001, Building 5 HuaDing, No.1 HuaKe 3  
Road, Binhai hi-tech Industrial  
Development Zone, Tianjin, China  
TEL: 86 22 26345859  
FAX: 86 22 83719955

Email [yzhao@aptdevelop.com](mailto:yzhao@aptdevelop.com)

Approval :

## Content

1	Product model.....	2
2	Suppliers.....	2
3	Specifications.....	2
4	Dimensions and Material.....	2
5	Features.....	3
6	Main page .....	3
7	Functional Description .....	4
	7.1 Power on/off .....	4
	7.2 Assist level.....	4
	7.3 Speed & Mileage mode .....	5
	7.4 Headlight / Display Mode .....	5
	7.5 Walking mode (6km) .....	5
	7.6 Data cleanup .....	6
8	Menu Page .....	6
	8.1 Display settings.....	6
	8.1.1 Language.....	7
	8.1.2 System .....	7
	8.1.3 Brightness.....	7
	8.1.4 Auto off .....	8
	8.1.5 Scenes .....	8
	8.1.6 Clock.....	9
	8.2 E-bike settings .....	9
	8.2.1 Start password .....	10
	8.2.2 Assist levels.....	11
	8.2.3 Wheel .....	11
	8.2.4 Battery .....	11
	8.2.5 Battery Ind .....	11
	8.2.6 Pow Ind .....	12
	8.3 Advanced setting.....	12
	8.4 Factory Setting.....	13
	8.5 Information.....	13
	8.5.1 Product Information.....	13
	8.5.2 Battery Information .....	14
9	Errors code.....	14
10	Assembly instructions .....	15
11	Install and use precautions .....	16
12	Copyright Notice .....	16

## 1 Product model

Model: 750CM

## 2 Suppliers

APT (Tianjin) Development Co., Ltd.

## 3 Specifications

- 3.2inch TFT screen(480\*RGB\*320)
- Wide-voltage range:
  - Low voltage: 20~70V
  - High voltage: 20~90V
- Multi-language support (6 languages)
- Rated operating current : 40mA, Maximum output current to controller: 100mA、off-leakage current <math><1\mu\text{A}</math>
- Operating temperature : -20~70°C、 Storage temperature -30~80°C
- IP65
- EN15194/2017
- RoHS

## 4 Dimensions and Material

Shell and bracket is made with ABS, panel is tempered glass.

Dimensions: host/L110mm\*W68.2mm\*H68mm

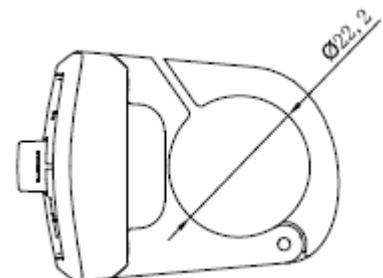

## 5 Features

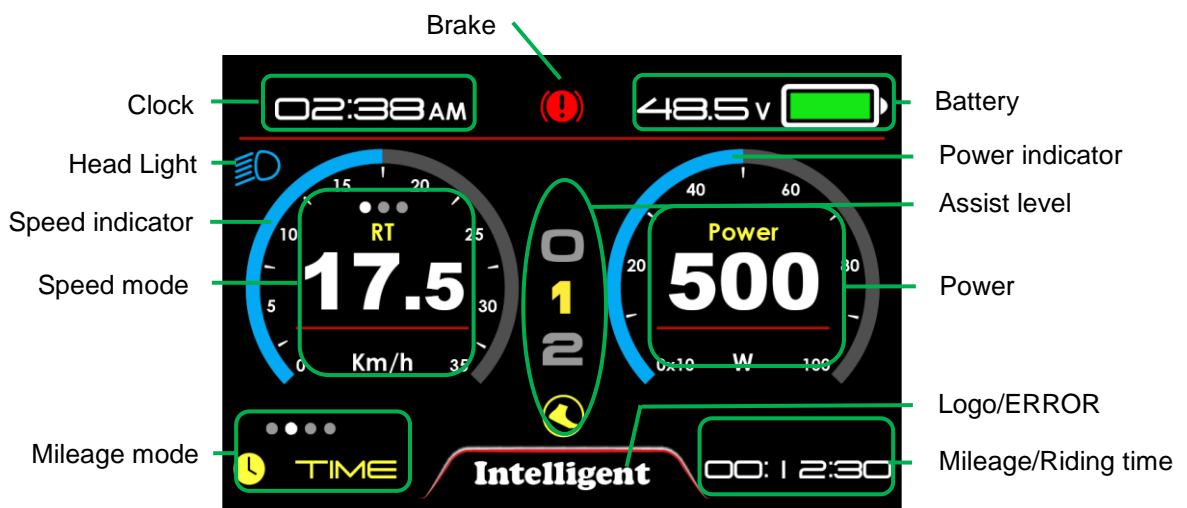

- **3.2inch TFT screen**
- **6 languages:**  
Czech, German, French, English, Italian, Spanish are supported.
- **Independent button, easy to operate**
- **Speed indicator:** Speed (Real-time), AVG Speed, MAX Speed
- **Metric / Imperial**
- **Smart battery indicator:** Capacity (percentage) or Voltage
- **Mileage indicator:** Odometer, Trip distance, Range
- **Clock indicator:** Built in battery, clock keeps running when power off
- **Brightness setting:** Day and Night Brightness can be set independent
- **9-level Assist:** 3-level/5-level/9-level/U optional.
- **Power/ Current indicator:** Real-time Power(W) or Current(A).
- **Errors Code tips**
- **6km walking**
- **Firmware upgrade:** Upgrade the Logo individually

## 6 Main page



- **Clock:** 24hour or 12hour clock
- **Head Light:** Head Light on/ off.
- **Speed Mode:** Real-time Speed, AVG Speed, MAX Speed, Km/h or MPH
- **Speed indicator:** The maximum indication can be set to 35km/h or 70km/h

according to the speed limit, and the display of real-time speed value is not affected when the driving speed exceeds the maximum indication.

- **Mileage Mode:** Odometer, Trip distance, Range, Riding time
- **Brake:** Show  when braking.
- **Smart battery Power indicator:** Provide a reliable battery Power indicator.
- **Assist Level:** 4 modes optional (3/5/9/U)
- **Power:** Real-time Power or Current.
- **Power indicator:** The maximum indication can be set to 1000W or 2000W according to the output of the battery, and the display of the actual power value is not affected when the power value exceeds the maximum indication.
- **Errors Code:** Show  when checking errors.
- **LOGO**

## 7 Functional Description

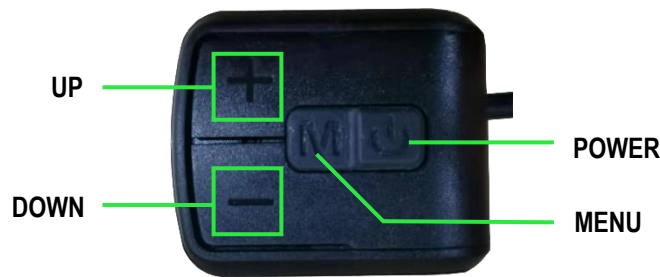

### 7.1 Power on/off

Press **POWER** button for 2 seconds, you can turn on/off the display. The Display can automatically turn off when there is no operating and riding for 5 minutes. (Length of time can be set , refer to 8.1.4 'Auto off')

\*Input pattern in first if pattern unlock was activated.

\*Display will be locked for 30 seconds after 3 times failed attempt.

### 7.2 Assist level

Press **UP/DOWN** button to change assist level, Top assist level is 9, 0 for neutral. Level quantities can be adjusted according to the customer requirements.

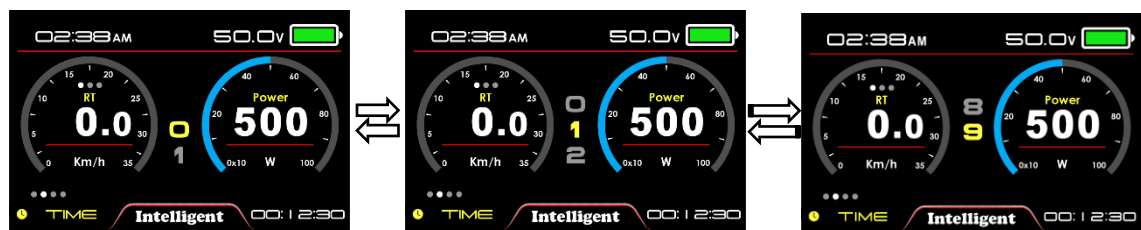

### 7.3 Speed & Mileage mode

Click **MENU** button can change the speed mode, **RT Speed**->**AVG Speed**->**MAX Speed**.

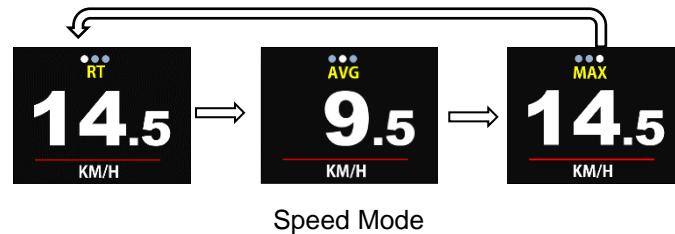

\* If there is no operation for 5 seconds, right item will restore to **RT Speed** automatically.

Click **POWER** button can change the mileage mode, **Trip**-> **Time** -> **ODO** ->**Range**.

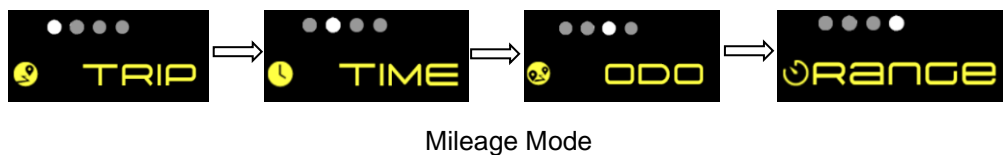

### 7.4 Headlight / Display Mode

Press and hold **UP** button for 2 seconds can turn on/off headlight, display will switch to the corresponding mode (Day or Night).

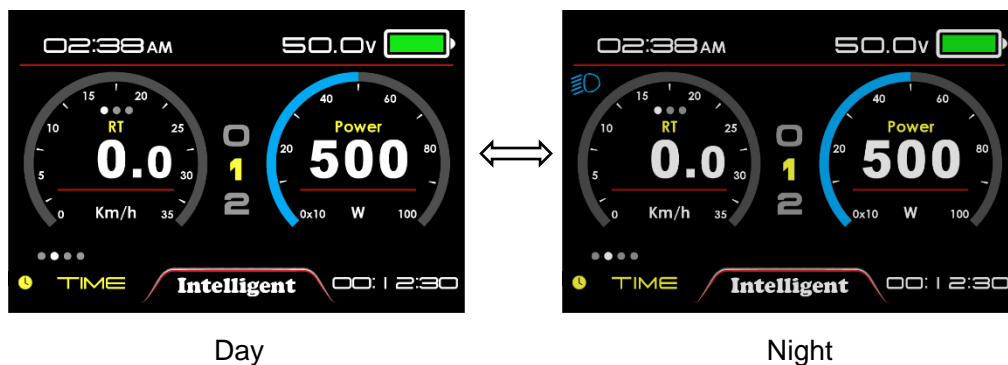

\* The brightness of the Display can be set according to the user's needs, Refer 8.1.3 Brightness.

\* The motor does not work when the battery voltage is low, Display still can keep the headlight on for a while when E-bike is in riding.

### 7.5 Walking mode (6km)

Press and hold **DOWN** button for 2 seconds can get into walking mode, show 'P' on screen, out of walking mode when releasing button.

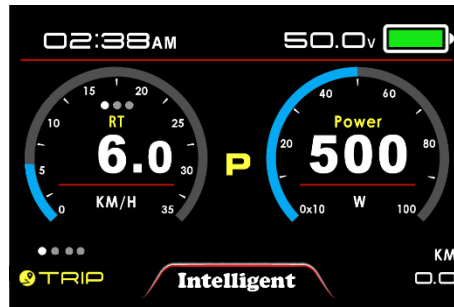

Walking Mode

## 7.6 Data cleanup

Press and hold **UP** & **DOWN** button together for 1 second can clean temporary data (TRIP, Riding-Time, AVG SPD, MAX SPD data).

- \* Temporary data is automatically saved when power off. Abnormal power outage will cause data lost.
- \* Restore Factory Mode (advanced settings in Menu Page) can clear temporary data (TRIP, Riding-Time, AVG SPD, MAX SPD, MENU settings) except ODO.
- \* ODO will reset to zero over 99999km. TRIP will reset to zero over 9999.9km.

## 8 Menu Page

Double press **MENU** button (press interval less than 0.3 second) can get into setting menus, press **UP/DOWN** button to change the parameter setting, press **MENU** button can switch to next item. Select EXIT or press **MENU** button twice to exit from menu.

- \* Display will automatically quit menu if there is no operation for 30 seconds.
- \* For safety reason, display will be locked on Main Page when riding (speed $\geq$ 2.0km/h), function of MENU will be deactivated.
- \* Display didn't save setting untill click MENU to confirm.
- \* Display doesn't quit parameter adjustment interface through pressing **MENU** button.

### 8.1 Display settings

Display settings include several items: Language, System, Brightness, Auto off, Scenes, Clock.

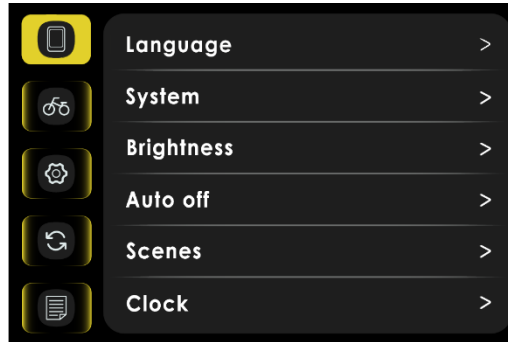

### 8.1.1 Language

6 languages are supported: Czech, German, French, English, Italian, Spanish. Default is English. Select language then click “Back” to confirm.

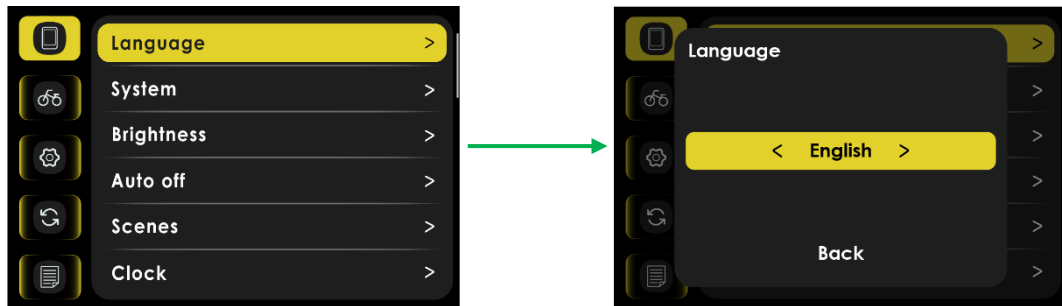

Language

### 8.1.2 System

Select Metric or Imperial.



Metric and Imperial

### 8.1.3 Brightness

Press UP/DOWN button to change brightness of backlight, 1 is darkness, 5 is brightness.



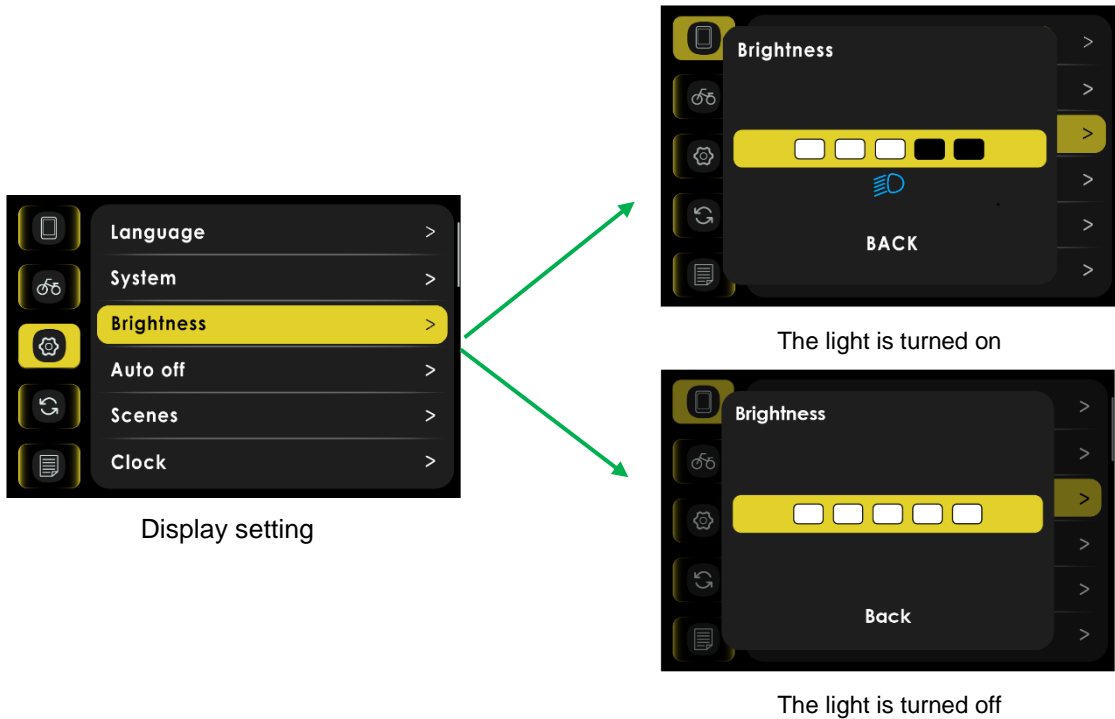

### 8.1.4 Auto off

This item enables to set the automatic shutdown time of the display, from 1 to 10min. Default value is 5 minutes, represents display shut down when there was no operation and riding for 5 minutes. OFF indicates that the display disables automatic shutdown.

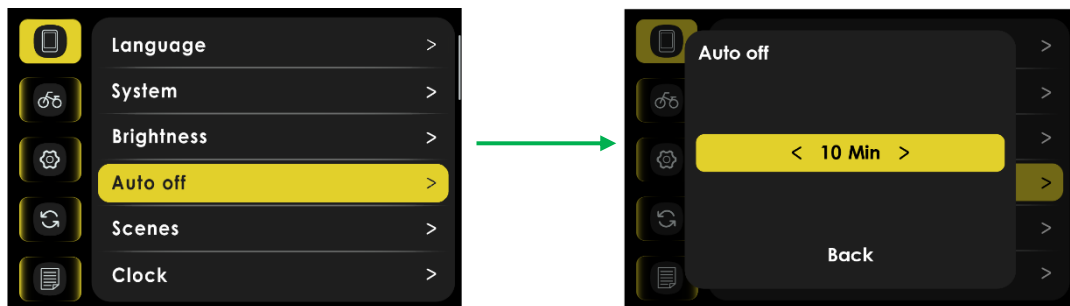

### 8.1.5 Scenes

Reserved, not yet in use.

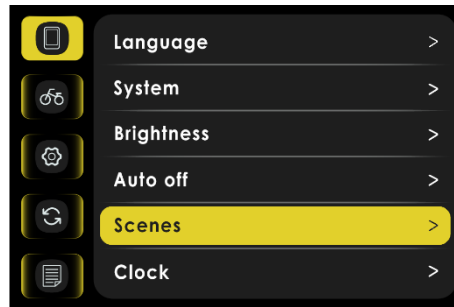

### 8.1.6 Clock

This item set date and time. You can choose Show-12 hour, Show-24 hour or hide Clock on Main Page through **UP/DOWN** button.

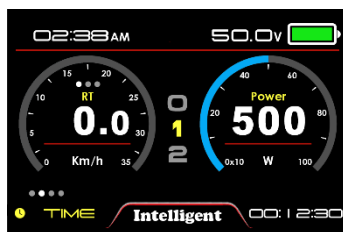
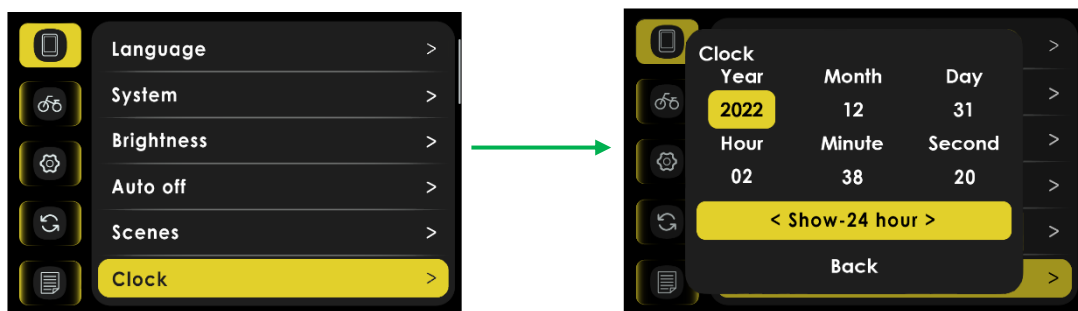

Show-12 hour

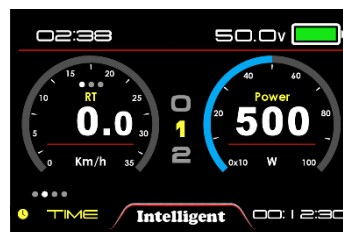

Show-24 hour

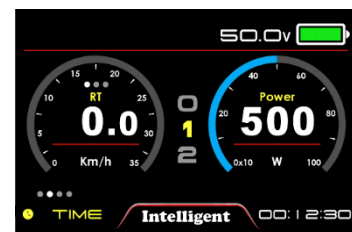

Hide

\* Note: When display was powered off, internal Button Battery can keep clock running. When display is power on, Button Battery will be charged by external battery. Clock may slow or stop if Button Battery is low, please charge the battery as follows: Set “Automatic shutdown” to “OFF” (Disable power off automatically), keep the display power on for 72 hours. Full charged Button Battery can keep clock running at least 3 months without charged.

## 8.2 E-bike settings

E-bike settings include several items: Start password, Assist levels, Wheel, Battery, Battery Ind, Pow Ind.

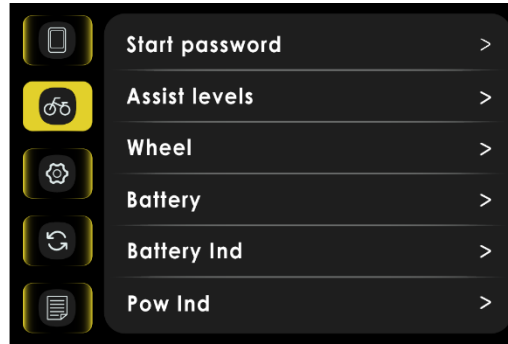

### 8.2.1 Start password

The start password includes two parameter settings, Start password, OFF/ON.

If you had set start password **ON**, you must input right password before power on.

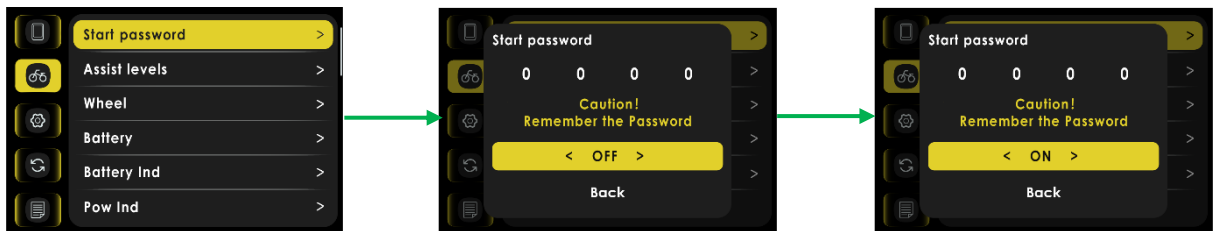

Turn on the start password function

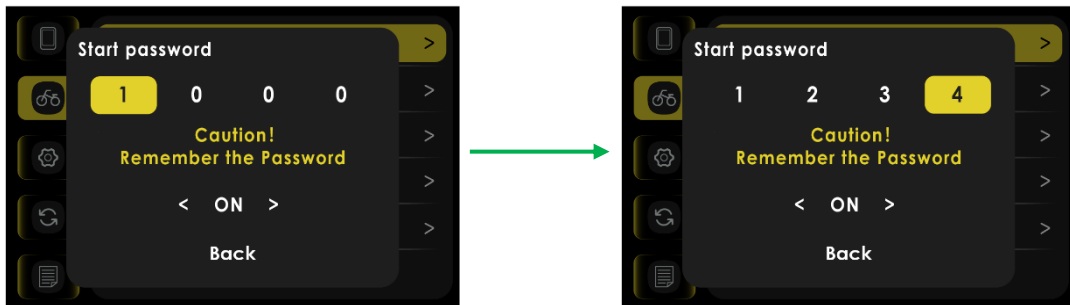

Start password setting page

You need to input the right password before start with 30 seconds.

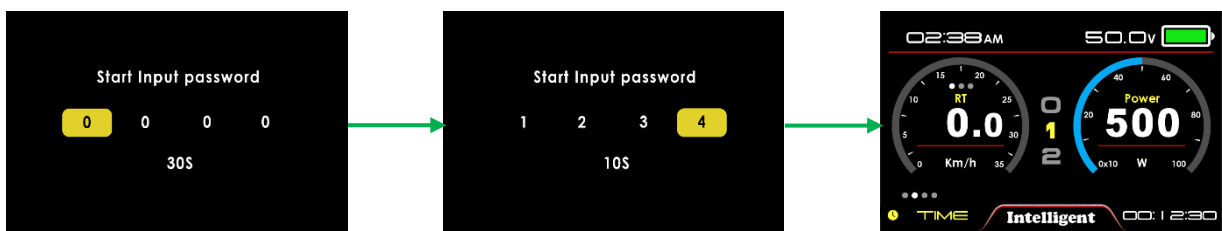

The boot page after setting the start password

\* Display will automatically shut down if the correct password is not entered within 30S. Press and hold the **POWER** button to shut down while entering the password.

\* Display will automatically shut down if the password was entered incorrectly 3 times.

### 8.2.2 Assist levels

This item can select assist levels, options are 3/5/9/U(6).

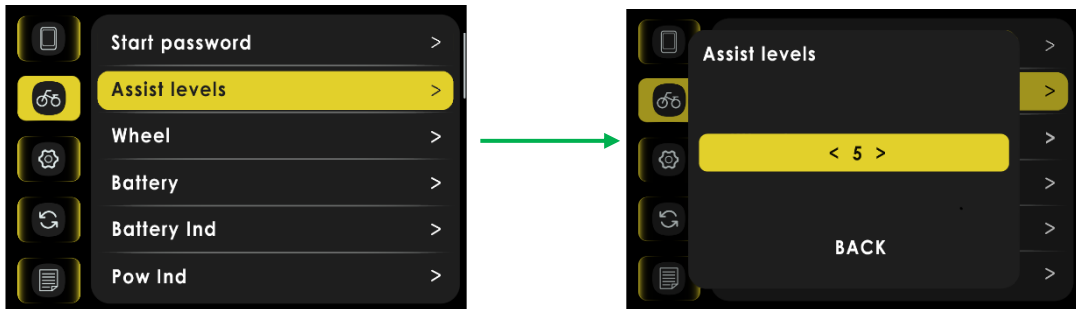

### 8.2.3 Wheel

This item can select wheel diameter, including 12/14/16/18/20/22/24/26/27/27.5/28/29/30/31 inch、51~250cm. Incorrect wheel diameter selection can lead to abnormal speeds.

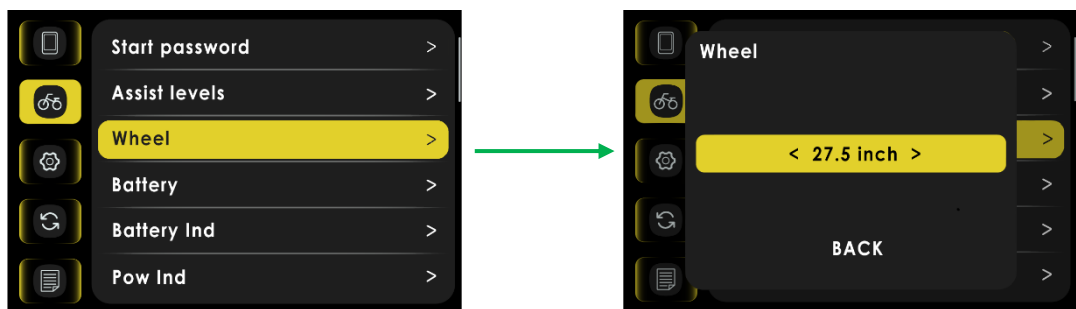

### 8.2.4 Battery

This item is unused in Bafang system.

### 8.2.5 Battery Ind

This item can select battery Ind setting, including OFF/Percent/Voltage.

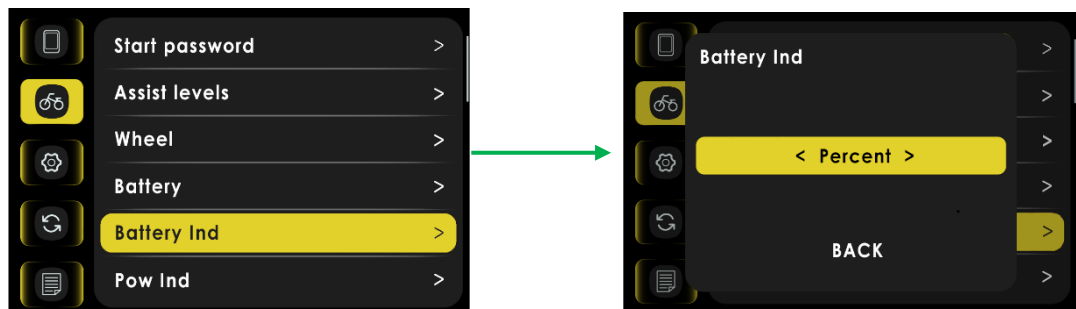

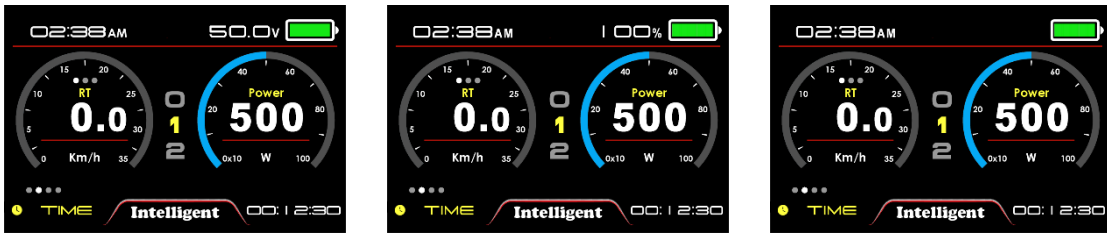

Voltage

Percent

OFF

Note: The voltage is the remaining voltage or percentage of the battery.

### 8.2.6 Pow Ind

This item can select power indicator on Main Page, 'OFF', 'Power(W)' and 'Current(A)'.

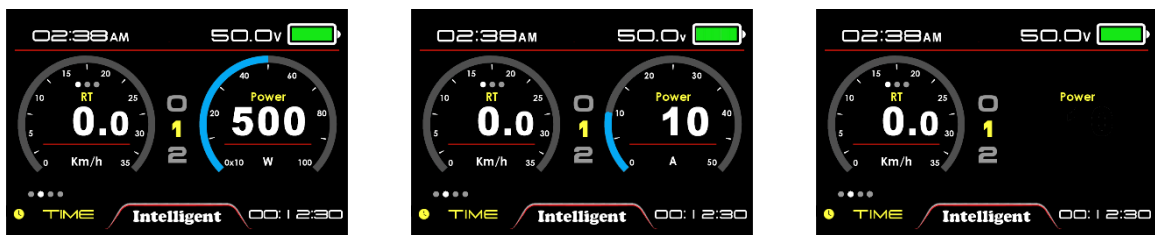
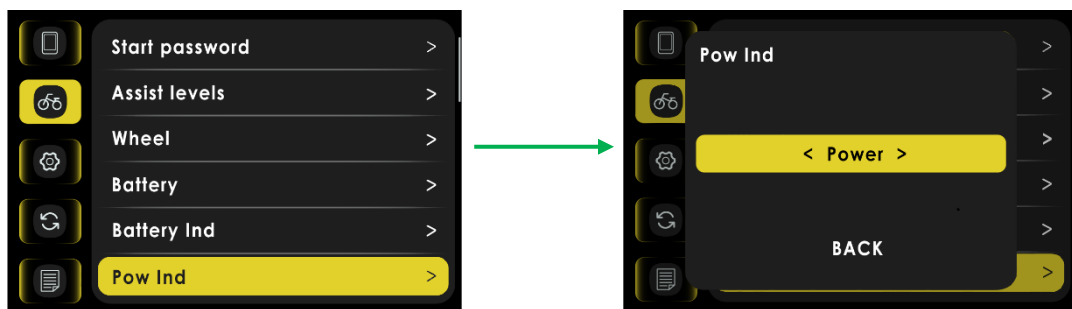

Output power (W)

Output current (A)

Power (OFF)

Note: Power indicator represent battery's output power (current), not motor.

### 8.3 Advanced setting

Advanced setting has password to prevent illegal modification, default password is '1919', password may be different according to request.

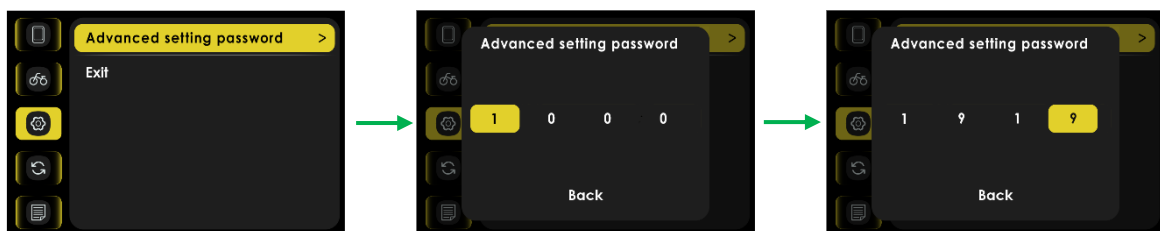

Input correctly password to enter advanced setting page, where you can adjust the speed limit, range 10km/h ~ 60km/h, 99m/h (6.2Mile/h ~ 37.3Mile/h, 61.5 Mile/h), and where you can see the error code messages of the last 10 times.



Note: The maximum speed is limited by the motor and controller, and it is not necessarily possible to reach the speed limit setting value.

### 8.4 Factory Setting

Select 'YES' will restore all setting to factory defaults.

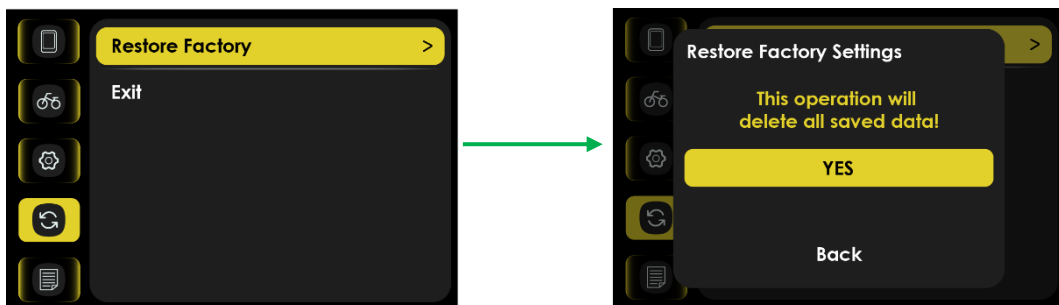

Note: ODO and CLOCK data are not cleared.

### 8.5 Information

The information display interface includes: Speed and Mileage Information, Product Information, Battery Information.

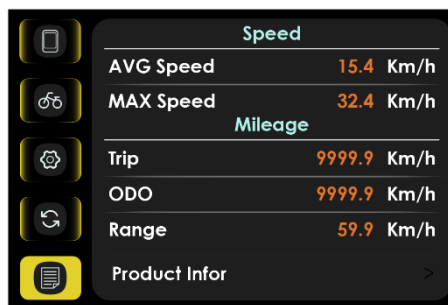

#### 8.5.1 Product Information

Product Information show Hardware Version, Software Version, Date.

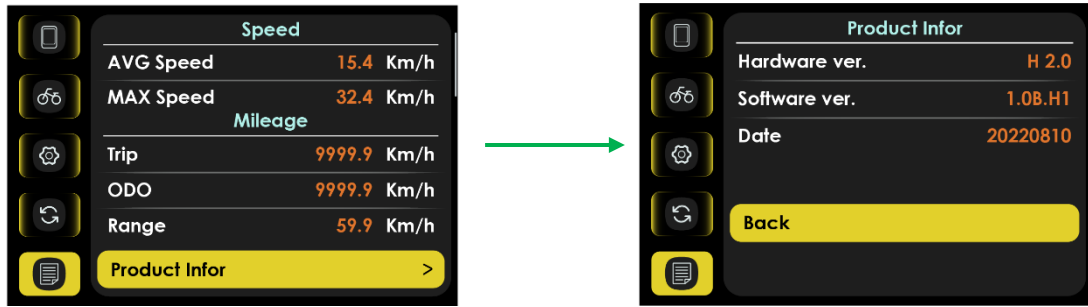

Product information

### 8.5.2 Battery Information

Battery Information can show Voltage, Capacity, Cycle times, Health, Relate ChgSta, Temperature, Remaining Capacity, Full Charge Capacity, Max Un-charge Times, Last Un-charge Times.

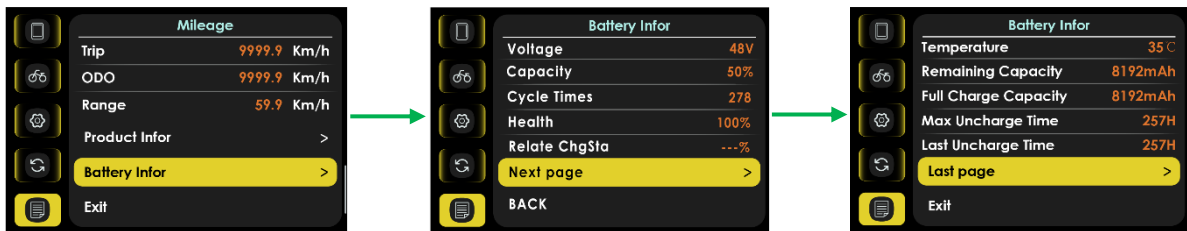

Battery Information

## 9 Errors code

Display shows error code and at the bottom of the screen when system checked abnormal.

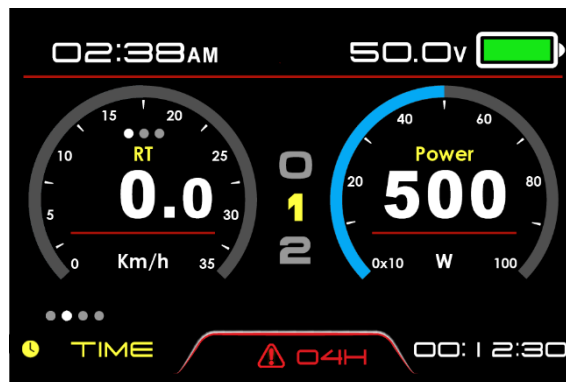

Error code prompt page

Error Code	Error description	Handle
04	Throttle error	Check throttle and connection
05	Throttle turn back fault	Check throttle and connection
07	Overvoltage protection	
08	Hall error	Check the hall connection
09	three-phase power error	Check three-phase power line connection

10	The controller is overheated	Stop using 10 minutes to restart
11	Motor overheating	Stop using 10 minutes to restart
12	Current sensor error	Check the sensor connection
13	battery temperature abnormality	Stop using 10 minutes to restart
14	Motor temperature sensor is abnormal	Check the sensor
15	Controller temperature sensor failure	Check the sensor
21	Speed sensor fault	Check the sensor
22	BMS Communication Error	Check the cable connection
23	Headlight error	Check the cable connection
24	Headlight sensor error	Check the cable connection
25	Torque sensor signal error	Contact the supplier
26	Torque sensor speed error	Contact the supplier
30	Communication Error	Check the cable connection

## 10 Assembly instructions

Please pay attention to the torque value, exceeding the maximum torque can damage the part.

Electrical or pneumatic tools is not recommended.

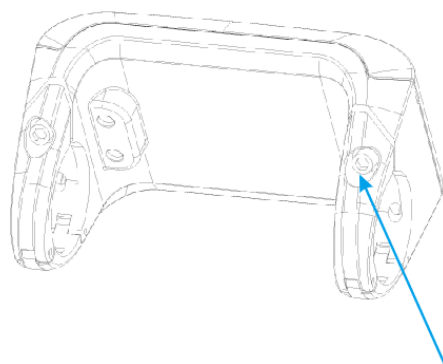

**M4\*10**  
**STD=0.1N.M**  
**MAX=0.2NM**

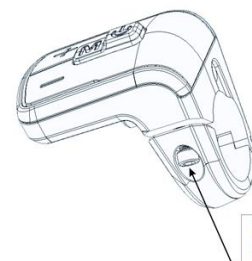

**M3\*10**  
**STD=0.25N.M**  
**MAX=0.4N.M**

Clamps suit for 3 sizes of handlebar, 31.8mm, 25.4mm, 22.2mm, there are transfer rings for 25.4mm and 22.2mm (marked with L or R), transfer ring must be assembled with the special directions, pay attention to the green arrow below.

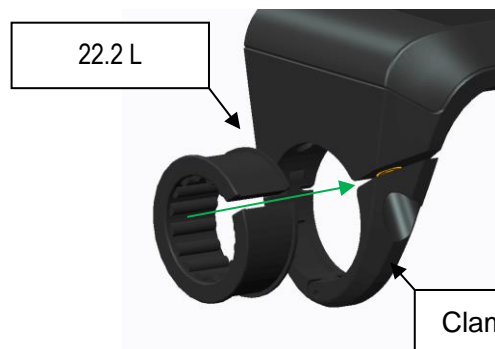



## 11 Install and use precautions

Do not adjust viewing angle before loose the screws.

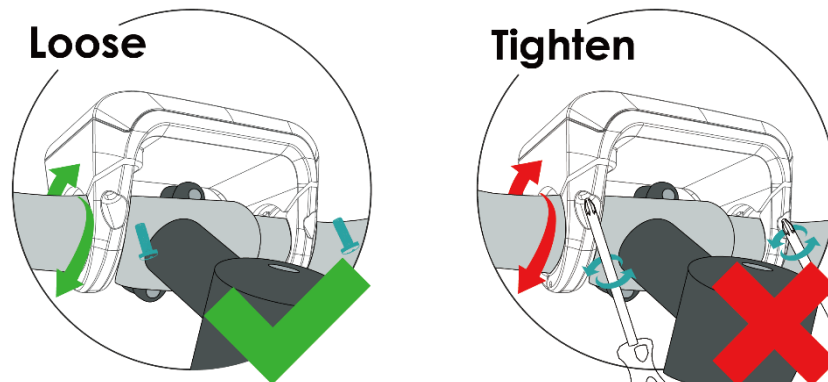

## 12 Copyright Notice

Questions about your e-bike, please contact with dealer firstly.

APT reserves the right to modify this specification file, without declaration in advance.

Content and Image owner: APT (Tianjin) Development Co., Ltd.

1001, Building 5 HuaDing, No.1 HuaKe 3 Road, Binhai hi-tech Industrial Development Zone, Tianjin, China

website: [www.aptdevelop.com](http://www.aptdevelop.com)